

1030110000 สเตรนแคลมป์แบบตรง 35-70 ตร.มม. , อลูมิเนียมแกนเหล็ก 35-50 ตร.มม.

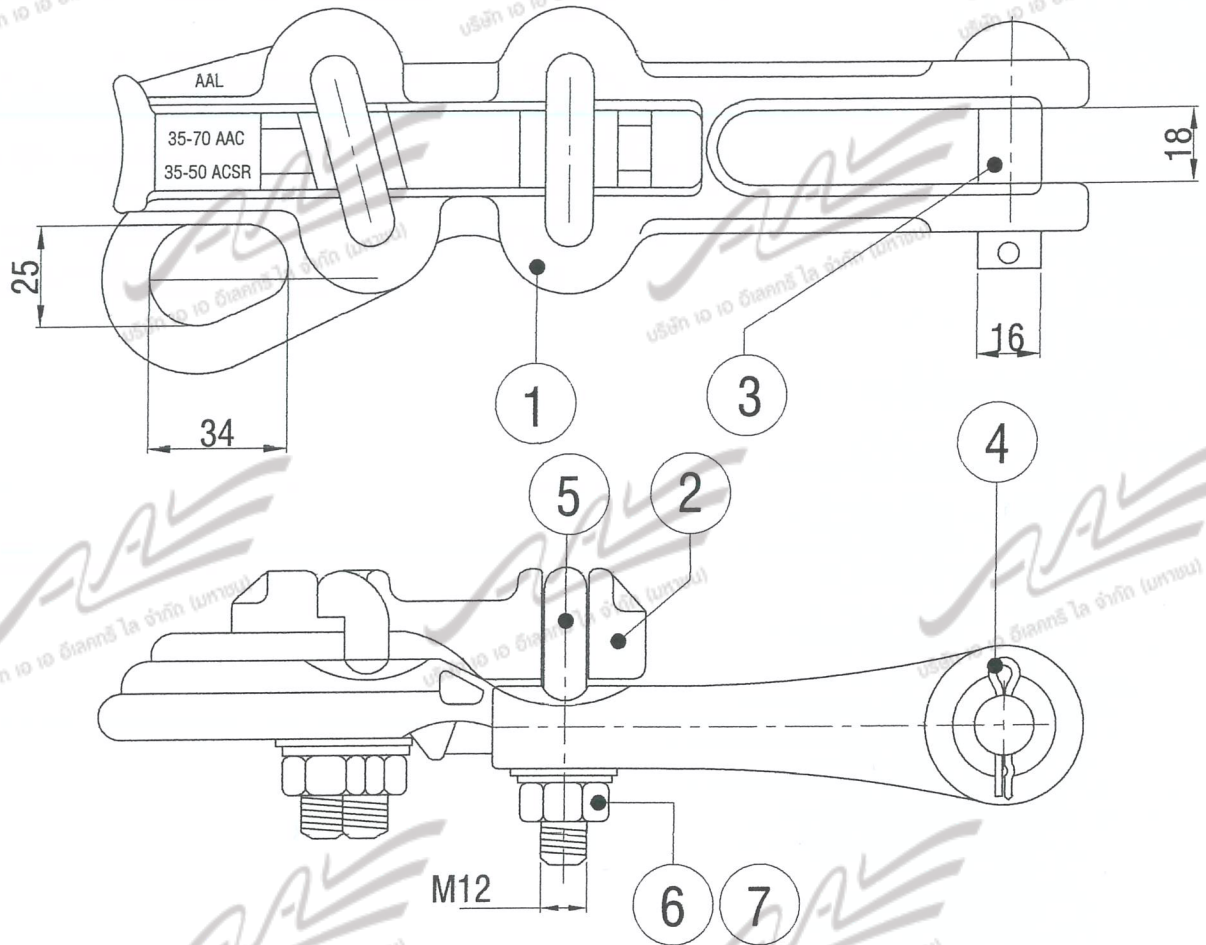

ITEM	DETAIL OF ASSEMBLY PART	MATERIAL	QTY.
1	BODY STRAIN CLAMP 35-70 Sq.mm	ALUMINIUM ALLOY	1
2	KEEPER STRAIN CLAMP 35-70 Sq.mm	ALUMINIUM ALLOY	1
3	DOMED M16 x 50 mm , Hole 5 mm	GALV.MILD STEEL	1
4	PRINT BRASS R , SSP-16	BRASS	1
5	U BOLTS M12	GALV.MILD STEEL	2
6	SPRING WASHERS M12	GALV.MILD STEEL	4
7	NUTS M12	GALV.MILD STEEL	4

**สำเนา** **ต้นฉบับ**

Tolerance ±5%

Note : Zinc coating thickness M16 to PEA standard > 53 µm

PEA Material No. 1030110000			
PEA Spec.No. R-564/2547			
PEA Drawing.No. -			
Rev.0 Feb,13,2015	Scale	Dimension	Sheet
Rev.1 Jan,1,2017	NTS	mm.	1 / 1
Material		See on drawing	
DWG No.		1030110000-S-01-01	
Revision			

A A ELECTRI LI PUBLIC CO.,LTD.

95 Moo5, Lumpo, Bangbuatong  
Nonthaburi, Thailand,11110  
02 158 4576 - 7  
www.aat2008.com

Title.

Dimension

Project.

1030110000

สเตรนแคลมป์แบบตรง 35-70 ตร.มม. ,  
อลูมิเนียมแกนเหล็ก 35-50 ตร.มม.